

The Shredding Solution for the Smooth Operation of Your Biogas Plant

BIOMASS SHREDDER BMS

The Biomass Shredder BMS is a vertical shredder that efficiently and homogeneously processes biomasses for biogas plants. The shredding and disintegration results in a higher gas yield and difficult substrates such as solid manure, silage, grass, straw, sugar beet or other crops can be made usable.



Your Advantages

Problem Solver for Biogas Plants

- Efficient particle size reduction of even the most difficult substrates
- Flexibility and economy using alternative raw materials
- High throughput rates of > 15 t/h (depends on substrate)
- Process optimisation through better pumping and agitating properties, minimisation of the floating layer

Reliable Operation and Long Durability

- Robust welded construction for continuous industrial operation (24/7)
- Impact parts and beaters made of wear-resistant materials such as Hardox and tungsten carbide
- Clog-free operation due to discharge in the bottom of the impact chamber
- Resistant to impurities, as no sharp tools are used

High Availability and Easy Maintenance

- Large maintenance door with platform ensures maximum accessibility
- Position of the maintenance door can be adjusted in 90° steps to suit the conditions on site
- Minimal wear costs due to replaceable shredding tools on the beater
- Easy to change wear plates due to outside screw connection
- Easy removal of heavy parts by crane traverse with chain hoist (option)

High Safety of Personnel and Plant

- Door securing with key transfer system
- Monitoring of unbalance, contaminant ingress and vibrations by means of vibration sensor
- Sensors for monitoring the bearing temperature

Technical Details

Type	BMS 1200	BMS 1500	BMS 1500-L
Throughput capacity (t/h)	up to 10	> 15	> 15
Rotor speed (rpm)	1000 - 1200	750 - 900	750 - 900
Number of beaters (pieces)	4	6	6
Dimensions and Weight			
Diameter housing (mm)	1200	1500	1500
Height housing (mm)	1290	1210	1510
Length x width x height (mm)	2535 x 1546 x 2440	2700 x 1730 x 2360	2700 x 1730 x 2660
Weight incl. motor (approx. kg)	3600	4800	4900
Drive			
Three-phase motor (kW)	55/75/90	110/132	110/132

Standard Supply and Options

Standard Scope of Supply:

- Door locking with key transfer system
- Belt drive with protective cover
- Base frame with antivibration mountings
- Bearing temperature monitoring
- Sensor for vibration monitoring
- Electrical components completely wired on terminal boxes
- Drive motor
- 1 set of beaters, fully assembled
- 1 set of impact parts, fully assembled
- Maintenance platform
- Maintenance opening can be varied in 90° steps
- Multi-coat painting

Option:

- Crane traverse for installation in the housing with chain hoist for the exchange of heavy parts such as the rotor

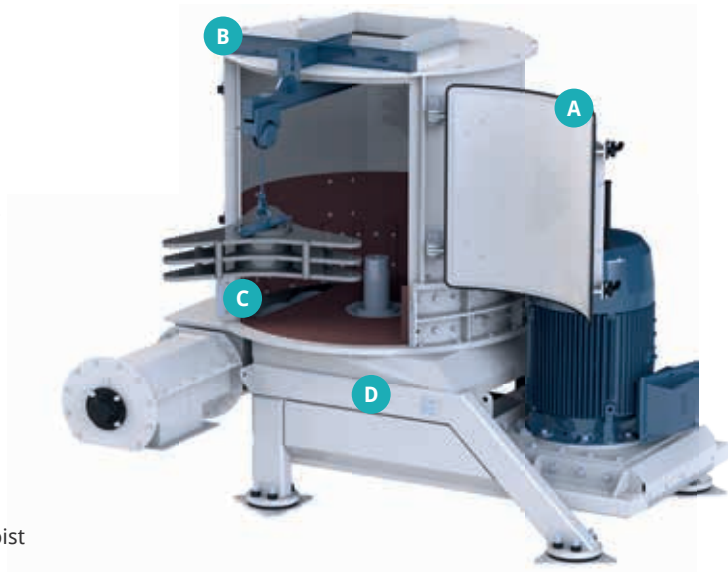

A Large maintenance door for optimal accessibility

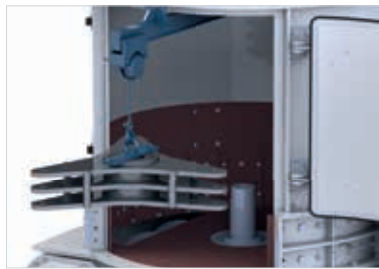

B Crane traverse

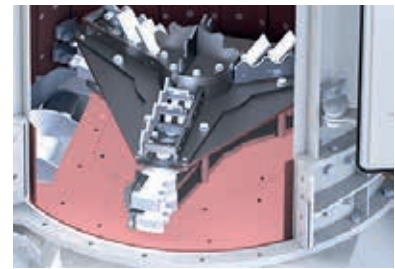

C Easy to change beaters and impact parts



D Maintenance opening can be varied in 90° steps