

Real-time monitoring of the particle size distribution

ONLINE PARTICLE SIZE CONTROLLER OPC

The Online Particle Size Controller OPC is installed at the outlet of the grinding system and continuously takes samples from the ground product. These samples are analysed by means of a camera system and the particle size is determined. The device is made entirely of stainless steel and has its own control cabinet for evaluating the measurement results.

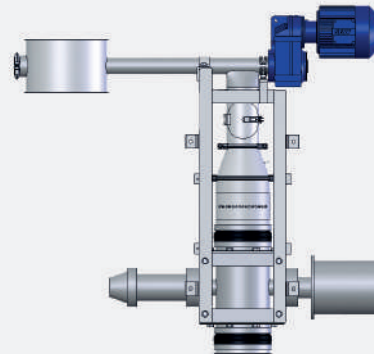

Your Advantages

Effective monitoring of the grinding process

- Detection of screen breakages or damages in the mill
- Detection of wear on beaters and screens
- Output of two individually definable alarm values in the case of deviations from the target particle size distribution, e.g. if the proportion of coarse or fine particles is too high
- Real-time measurement for immediate reaction

Increase of the plant availability

- Optimisation of maintenance intervals due to particle size changes during operation
- Predictive maintenance of the mill possible

Suitable for many applications

- For free-flowing bulk materials of all kinds

- Purge air connection for cleaning, can also be used for greasy and sticky products
- Return of the analysed sample into the process or discharge for traceability possible
- No recalibration required when changing products or formulations

Simple integration into the grinding system

- Can be integrated into both new and existing systems
- Simple connection in a vertical pipe via flared flange
- Evaluation via own electronics
- Full operability via web interface
- Integration into the process control system possible

Technical Details

Type	OPC
Analysis method	optical
Measuring range (µm)	160 to 6000
Power supply (V)	230
Compressed air (water- and oil-free)	6 bar, approx. 10 Nm ³ /h
Signal input	external start signal, LAN connection
Signal output	2 alarm values, fault message, LAN connection
Dimensions	
Measuring column (mm)	1500
Sampling screw (mm)	1500
Diameter pipe section/flange	300
Drive	
Gear motor sampling screw (kW)	0.75

Standard Supply and Options

Standard Scope of Supply:

- Sampling screw incl. gear motor
- Camera system
- Control cabinet with electronics
- User interface with touch panel/web interface
- Software for particle size analysis
- Made entirely of stainless steel
- Support for installation in a pipe
- Unit in ATEX design according to zone 20 (II 1 D) inside and 22 (II 3 D) outside, control cabinet for installation outside an ATEX zone

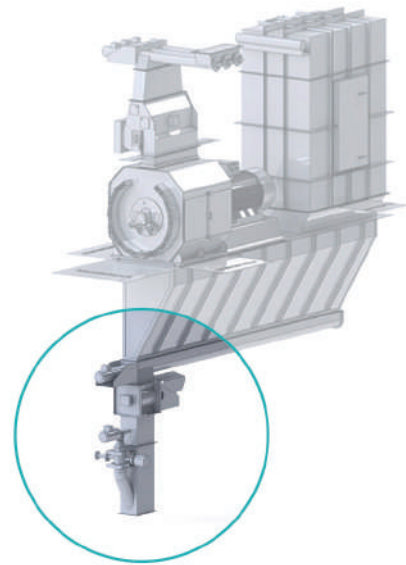

Integration of the Online Particle Size Controller OPC into the grinding module

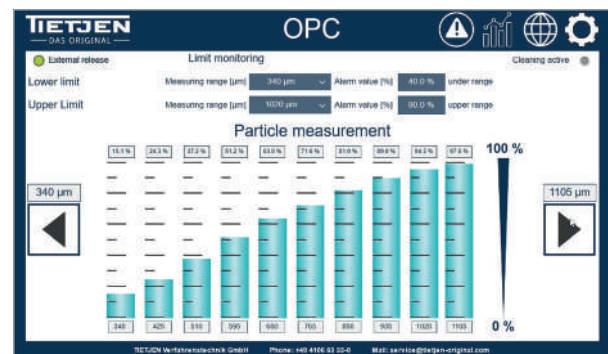
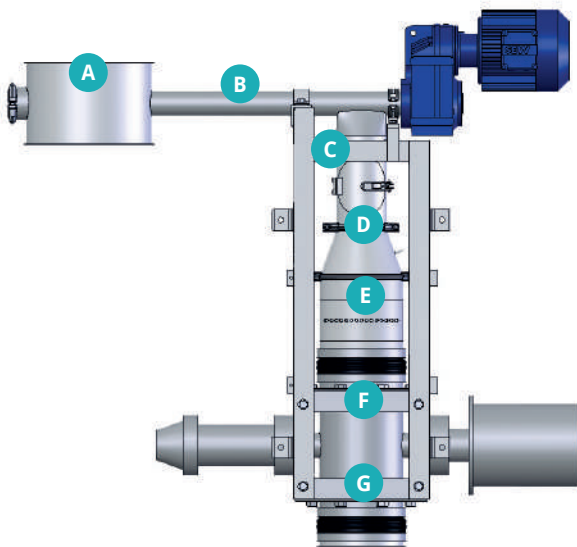

H Operation via web interface

- | | |
|--|---|
| A Pipe section for installation | B Sampling screw |
| C Inspection opening | D Purge air connection |
| E Sample preparation | F Camera system for particle measurement |
| G Sample return/discharge | H Software |